

060R9753

060R9753

KP 15, 17W, 17B: R 12, R 22, R 500, R 502
 KP 15A: R 717 (NH₃)

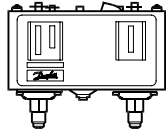

Fig. 1 KP 15, 17

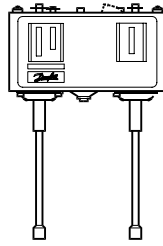

Fig. 2 KP 15, 17

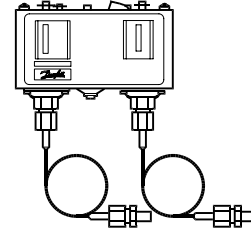
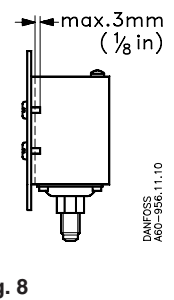
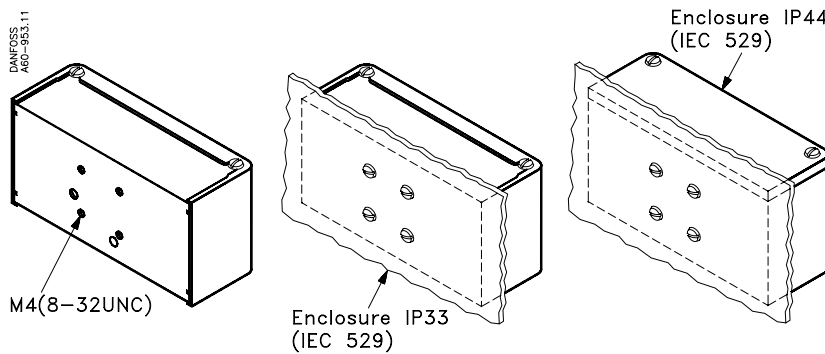
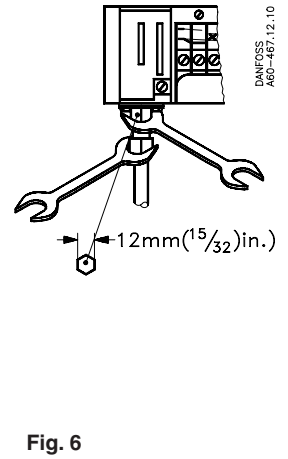
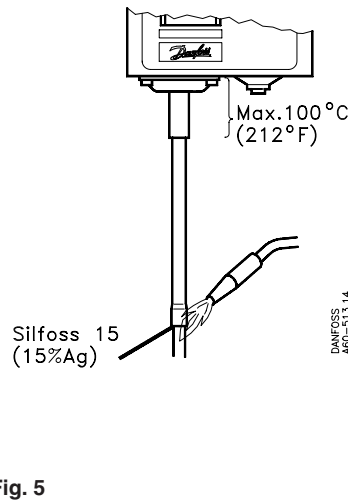
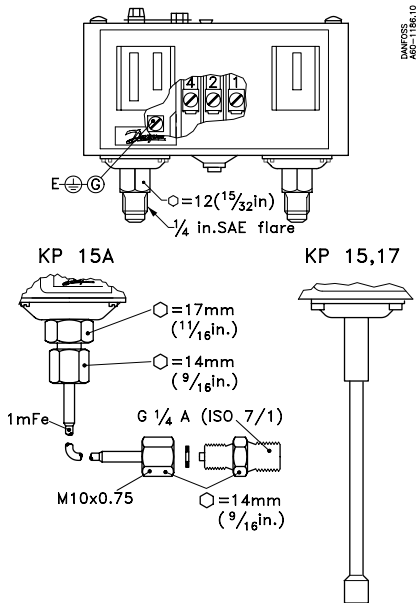
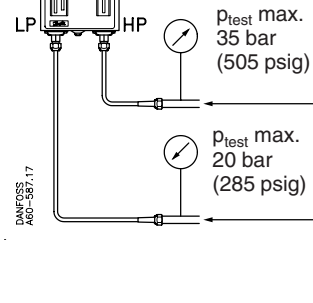
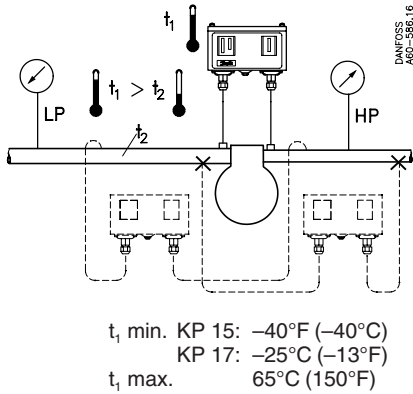

Fig. 3 KP 15A



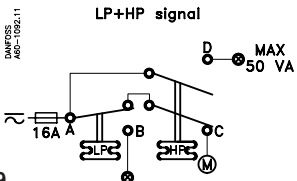
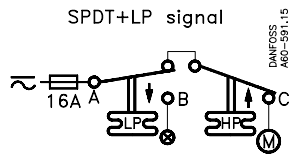

Fig. 9

When used acc. to UL regulations

UL Listed refrigeration controller 61B5

Con- tacts	Voltage AC DC	FL A	LR A	Resist. load	Pilot duty
A-B	240	8	48	8A	3A
A-C	120	16	96	16A	
	240				12W
A-D	240				50VA

Use copper wire only
Tightening torque 20lb.in.

LR 112A	AC1 16 A	DC 11
	AC3 16 A	12 W
	AC11 10 A	220 V≈
	400 V≈	

Fig. 10

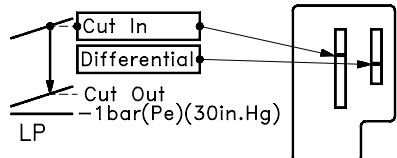
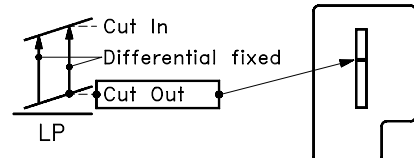
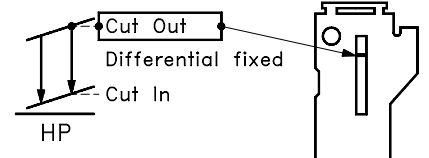

Fig. 11

LP
KP 15, 15A, 17W, 17B



LP
KP 15, 15A



HP
KP 15, 15A, 17W

Manual test

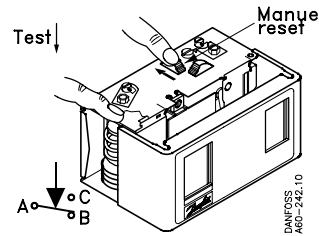
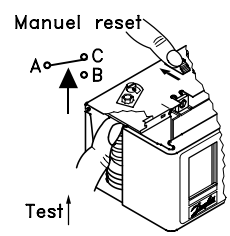
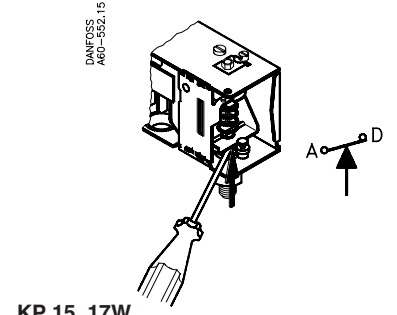

Fig. 12

KP 15



KP 15, 17W

Konvertibel reset / Convertible reset / Austauschbares Reset / Réarmement convertible

KP 15 060-1154, 060-1220, 060-1261, 060-1263, 060-1283

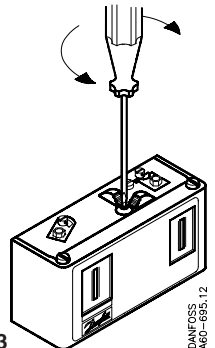
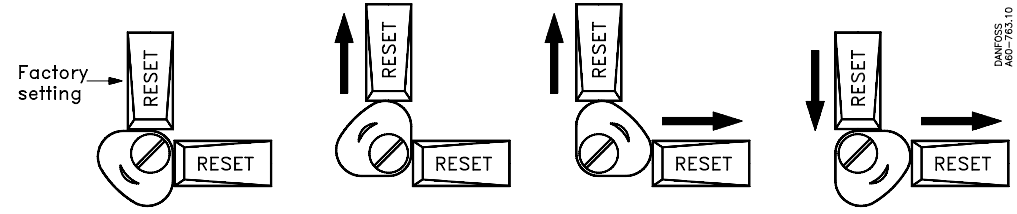

Fig. 13



LP-man.
HP-man.

LP-auto.
HP-man.

LP-auto.
HP-auto.

LP-man.
HP-auto.

Type	Range	PB	MWP
KP 15	LP: -0.2 → 7.5 bar	17 bar	250 psi
	HP: 8 → 32 bar	35 bar	460 psi
KP 15 Reset	LP: -0.9 → 7 bar	17 bar	250 psi
	HP: 8 → 32 bar	35 bar	460 psi
KP 17	LP: -0.2 → 7.5 bar	17 bar	250 psi
	HP: 8 → 32 bar	35 bar	460 psi

Fig. 14

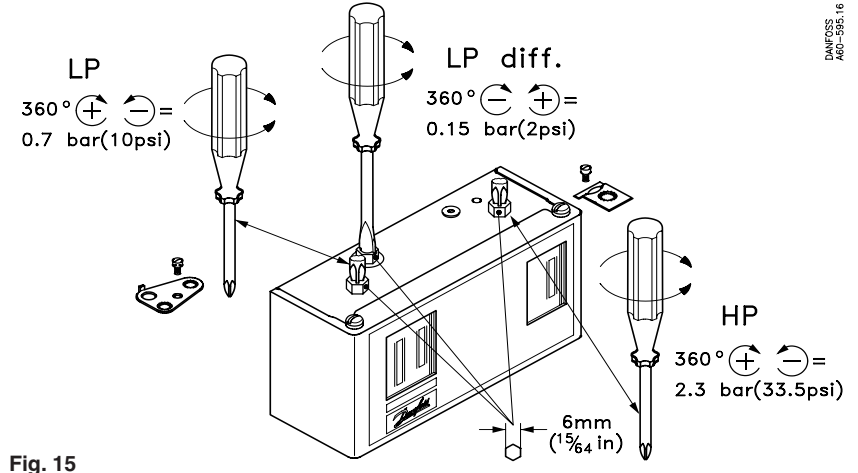

Fig. 15